

Brass Ball Valve



SYSTEM **IFAN**

Catalogue

Technical Information

1. GENERAL INTRODUCTION

1.1 Design and manufacture

*IFAN ball bibcocks and ball valves are manufactured within an **ISO 9001: 2008 Accredited Quality System** with the most modern hi-tech production systems as regards hot forging as well as mechanical machining and process automation.*

They are the result of a production cycle carried out entirely in IFAN, starting from design right through to manufacturing.

Sizing takes place with the aid of advanced computerised instruments: from the 3D design to structural verification with FEA (Finite Elements Analysis) methods.

The manufacture (hot forging, the raw casts deburring and mechanical machining) is entirely carried out in IFAN and using equipment (dies-vices-tools) which has also been designed and made in-house by a CAD-CAM process.

IFAN ball valves have no preferential fitting direction, so they can be orientated in any direction.

They also have a command stem fitted inside so they cannot be ejected by the valve (blow-out proof construction).

This choice furthermore prevents any external tampering.

1.2 Fields of use

*For the seals in **NBR70** the following table shows the general chemical compatibility with some of the substances most commonly circulated in systems where ball valves are used.*

Depending on the series chosen, IFAN ball bibcocks and ball valves can be used in hydraulic circuits for the ad-duction of hot and cold water in industrial or civil installations, or systems and equipment for gas adduction, for example:

- a) Sanitary installations**
- b) Agricultural applications**
- c) Heating systems**
- d) Distribution systems**
- e) Pipelines for not corrosive and not abrasive fluids**
- f) Gas pipeline systems**

They are made conforming to Ministerial Decree 174 of 06/04/2004 and so can also be used for the passage of potable water. For use with flammable gasses on the contrary there are specific ball valve versions complying with EN331 standard. The last ones can be used with natural gas (1st family), methane gas (2nd family), liquid gas (3rd family) and in general all the gasses covered in standard EN 437, in the following systems:

- 1) Domestic and industrial equipment**
- 2) Heating systems**
- 3) Gas distribution systems in general**
- 4) Low and medium pressure gas installations**

All IFAN ball bibcocks and ball valves are of course suitable for use with fluids other than water and gas, as long as these fluids are compatible with the characteristics of use and the materials described in this catalogue.

NBR CHEMICAL COMPATIBILITY	
SUBSTANCE	LEVEL
Mineral oils	G
Light combustible oils, diesel	G
Combustible gas (methane, GPL)	G
Aliphatic hydrocarbons	G
Vegetable and animal oils	G
Hot and cold water (up to + 100 °C)	G
Sea water	G
Saline solutions	G
Fuels with a high aromatic content	A
Some types of Freon	A
Diluted acid solutions	A
Petroleum based hydraulic fluids	A
Diester based synthetic lubricants	A
Benzene and chlorinated hydrocarbons	P
Aromatic hydrocarbons (Benzol)	P
Phosphoric-ester-based hydraulic fluids	P
Glycol-based brake fluids	P

G / GOOD A / AVERAGE P / POOR

1.3 Materials

The constructional materials are those specified in the following table:

Position	Name	Material	Treatment
A	Body	UNI EN12165 CW617N	Nickel plated or normal
B	Ball	UNI EN12164 CW614N o UNI EN 12165 CW617N	Diamonded and thick-chromed
C	Seats	P.T.F.E.	-
D	Coupling	UNI EN12165 CW617N	Nickel plated or normal
E	O-rings	NBR 70	-
F	Stem	UNI EN 12164 CW614N	-
G	Nut	Iron	Galvanised
H	Flat straight handle	Iron	Galvanised+insulating sheath in PVC
H1	Straight handle in aluminium	Aluminium	Painted
H2	T Handle	Aluminium	Painted

Ball valve composition

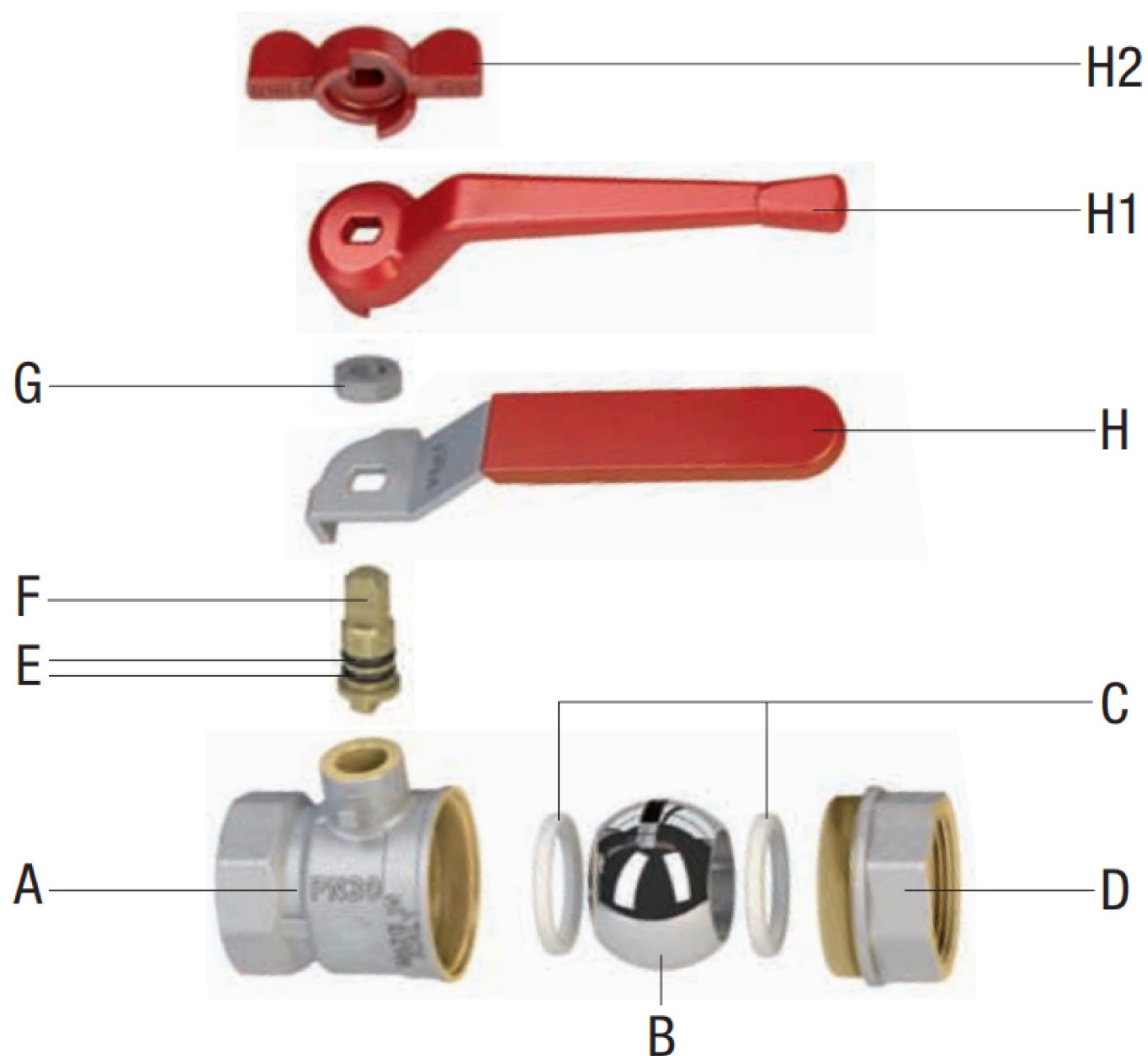

IFAN ball valves are divided into five families, whose con-structional characteristics are summarised in the table below. The ball bibcocks instead all belong to the same family .

FAMILY	FITTINGS	FLOW	PN max [bar]	DN	EN331
3200	ISO228	STANDARD	30	Min: 14 Max: 47	No
3800	ISO7-EN10226	STANDARD	50	Min: 14 Max: 47	No
3300	ISO228	TOTALE / TOTAL	40	Min: 15 Max: 50	No
3400	ISO7-EN10226	TOTALE / TOTAL	50	Min: 15 Max: 50	No
3900	ISO7-EN10226	TOTALE / TOTAL	5-20	Min: 15 Max: 50	Yes
3500	ISO7-EN10226	RIDOTTO / REDUCED	30	Min: 10 Max: 15	No

1.5 General technical characteristics

BODY AND FITTING

Made in brass UNI EN 12165 CW617N, hot forged and sandblast-ed. Mechanically machined in order to obtain a double seal (metal+ Loctite® glue).

THREADS

Female: these threads can be of the not pressure-tight on the thread type, in this case they are parallel and conform to UNI EN ISO 228 Standard;
or they can be pressure-tight on the thread, and in this case are again parallel but conform to UNI EN 10226 (ISO 7) Standard.

Male: these threads can be of the not pressure-tight on the thread type, in this case they are parallel and conform to UNI EN ISO 228 Standard; or they can be pressure-tight on the thread, and in this case are tapered and conform to UNI EN 10226 (ISO 7) Standard.

JOINTS

In all ifan ball valve families there are Female-Female, Male-Fe-male and Male-Male versions. Then there are specific models with ring joints for copper pipes or with a three-piece joint. All valves have in-line inlet and outlet joints, except the models Art. Ball bibcocks instead have a male threaded inlet connection and a hose tail outlet .

LEVER HANDLE

It can be made in die-cast aluminium, with a lever or butterfly shape, and in both cases it is epoxy powder painted and embossed with the IFAN brand .
Alternatively it can be made in Iron, with a PVC insulat-ing coating, embossed with the IFAN brand .

BALL SEATS

All the seats and relative balls are made in such a way as to guarantee a closing angle of >7°(dead angle).

PRESSURE

The maximum nominal operating pressure for use with liquids is **30 bar, 40 bar** or **50 bar**, depending on the models. For use with flammable gasses the maximum operating pressure (MOP) is 5 bar, rising to 20 bar for 3rd family gasses (e.g. propane, butane and in general gasses known as "liquid gasses", which at storage pressure are in fact in a liquid state).

TEMPERATURE

In general is the elastomeric seals (O-Rings) to condition the temperature range of the ball valves and ball bibcocks in use.

ifan ball valves and ball bobcocks are fitted with NBR70 seals type approved for use with potable water and gas. The permitted temperature range is $-25^{\circ}\text{C} \div +125^{\circ}\text{C}$. However the gas certification standard (EN331) limits the range of use for ball valves to $-20^{\circ}\text{C} \div +60^{\circ}\text{C}$.

MARKINGS

All ball valves for water are marked as follows: Ifan - MADE IN xx - DNxx - THREAD - PNyy, where the DN value is the nominal flow diameter in mm and the value PN is the maximum working pressure. Those for gas have a double marking for the pressure: W-PNyy indicates the maximum pressure with water, while MOP5-20 indicates the pressure range with gas (as indicated in the paragraph PRESSURE). For ball bibcocks instead the marking is Ifan - MADE IN xx- THREAD - PNyy, where the value PN is the maximum working pressure.

2. REFERENCE STANDARDS

Depending on the constructional aspect in question, there are different reference standards which valves and ball bobcocks comply with: see the table

	VERSIONS FOR WATER	VERSIONS FOR GAS
THREADS	UNI EN ISO228 / UNI EN10226 (ISO 7)	UNI EN10226 (ISO 7)
NOMINAL DIAMETERS	EN13828	EN13828
O'RINGS	WRAS (BS 6920); KTW (1.3.13 D2); DVGW-W270 E (02/2007); NSF (Standard 61; CLP (DGS/VS4 n° 2000/23 – FDA (177.2600-21)	DVGW DIN EN 549 B2 DVGW VP 406-A 7
PTFE SEALS	FDA-CFR 21 – parti 170 a 199 articolo 177.1550 ; DVGW W 270 (11/2007)	Not necessary
LUBRICANTS	EN377	EN377
BRASS	EN12614 / EN12165	EN12614 / EN12165
VALVE (up to DN25 included)	EN13828	EN331 + 90/396/CE (GAD)
VALVE (beyond DN25)	EN13828	EN331 + 90/396/CE (GAD) + 97/23/CE (PED)

3. SPECIFICATION

LL1063 1/4"-4"
hot forged brass ball valve

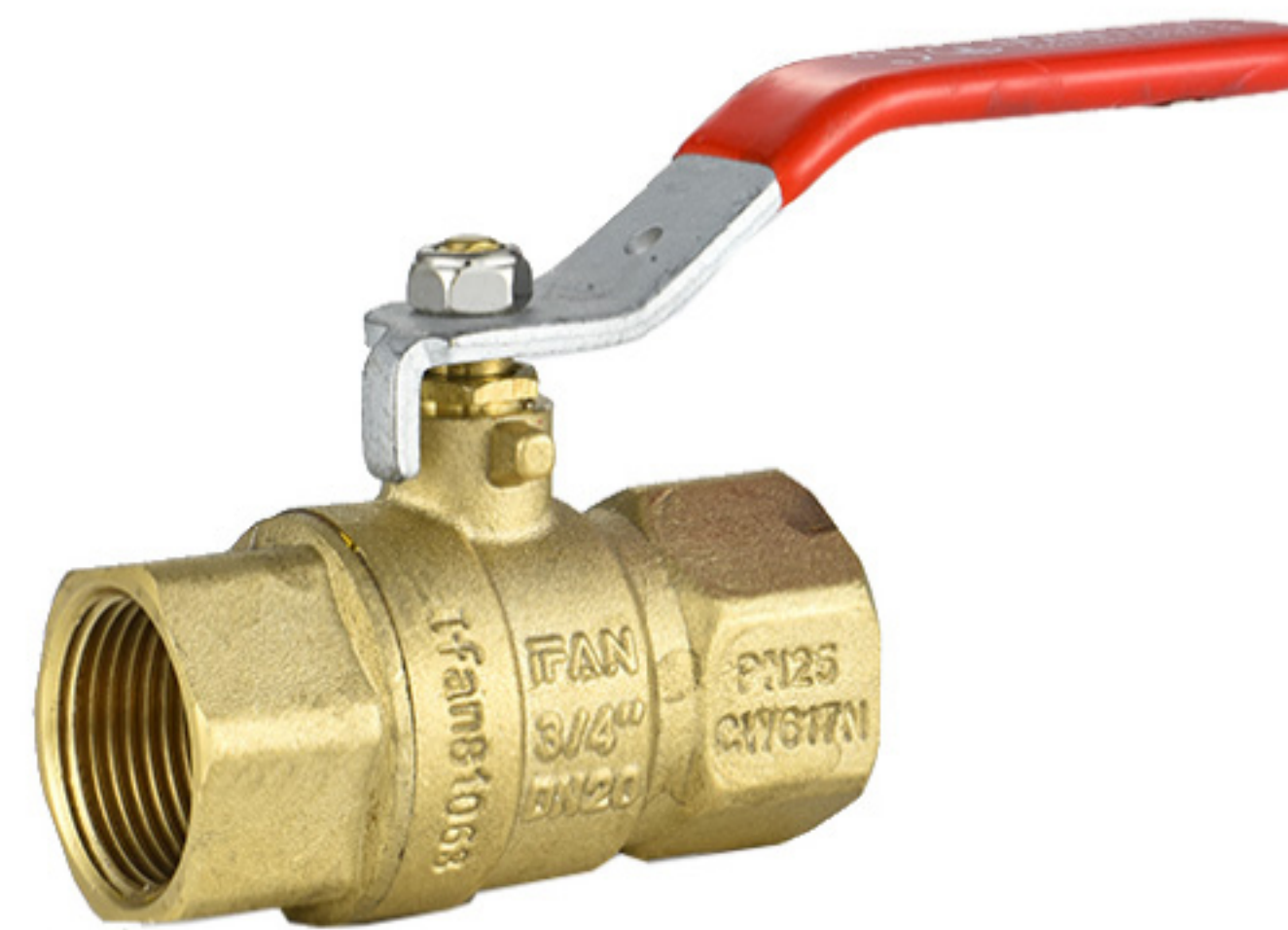

Quality

- 24h 100% seal test guaranteed
- Dual sealing system allows valve to be operated in either direction making installation easier
- No metal-to-metal moving parts
- No maintenance ever required
- Handle clearly shows ball position
- Silicone-free lubricant on all seals
- Chrome plated brass ball for longer life
- Handle stops on body to avoid stresses at stem

Body

- Hot forged sand blasted, unplated brass body and cap sealed with Loctite® or equivalent thread sealant
- Finest brass according to EN 12165 and EN 12164 (formerly DIN 17660 and UNI 5705-65) specifications

Stem

- Blowout-proof nickel plated brass stem
- Two FPM O-rings at the stem for maximum safety

Sealing

- Pure PTFE self-lubricating seats with flexible-lip design

Threads

- ISO 7/1, BS 21 BSPT taper female by female threads



Flow

- One size reduced port compact design

Handle

- Geomet® carbon steel handle with thick PVC dip coating.
- Handle coating offers both thermal and electrical protection
- WARNING:** do not exceed reasonable temperature and/or electrical load
- Handle removable with valve in service

Working pressure & temperature

- 40 Bar (600 PSI) non-shock cold working pressure
- -40°C (-40°F)/+170°C (+350°F)
- **WARNING:** freezing of the fluid in the installation may severely damage the valve

Options

- NPT taper ANSI B.1.20.1 threads (s. 71 model with packing glands)
- Stem extension
- T-handle
- Oval lockable handle
- AISI 430 stainless steel handle
- Patented locking device
- Stubby handle
- IFAN memory stop designed to be installed with our stubby handle

Upon request

- AISI 316 stainless steel ball Glass filled PT
- FE seals
- Custom Design
- Male by female threads

PED directive

- According to 2014/68/UE module A: it cannot be used with dangerous gases in sizes larger than 25 mm

Approved by or in compliance with

- GOST-R (Russia)
- Hygiene and epidemic center in Moscow city (Russia)
- RoHS Compliant (EU)

NOTE: approvals apply to specific configurations/sizes only

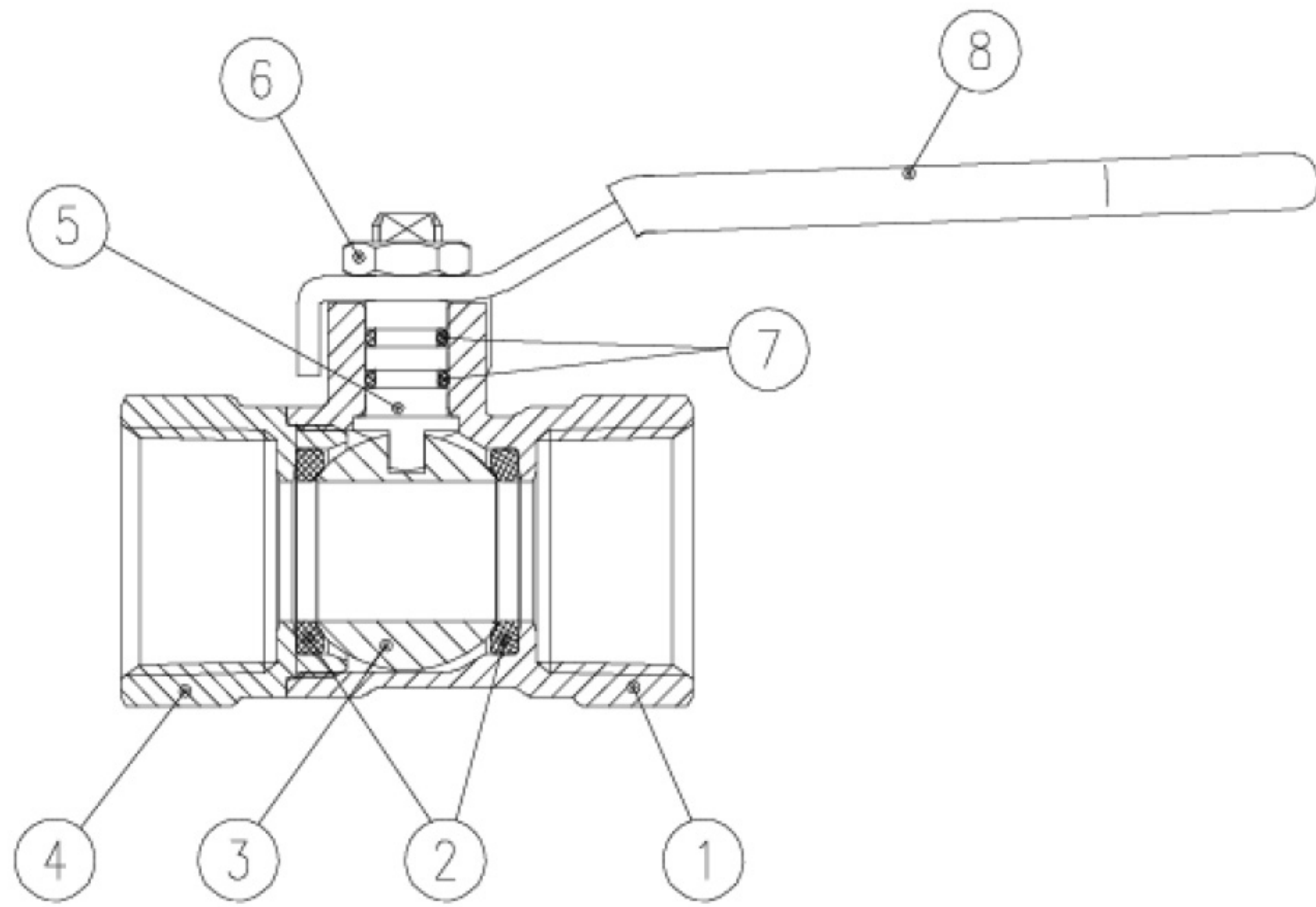

	PART DESCRIPTION	Q.TY	MATERIAL
1	Unplated body	1	CW617N
2	Seat	2	PTFE
3	Chrome plated ball	1	CW617N
4	Unplated end-cup	1	CW617N
5	Nickel plated stem O-ring design	1	CW617N
6	Geomet nut	1	CB4FF
7	O-ring	2	FPM
8	Red PVC coated Geomet handle	1	DD11

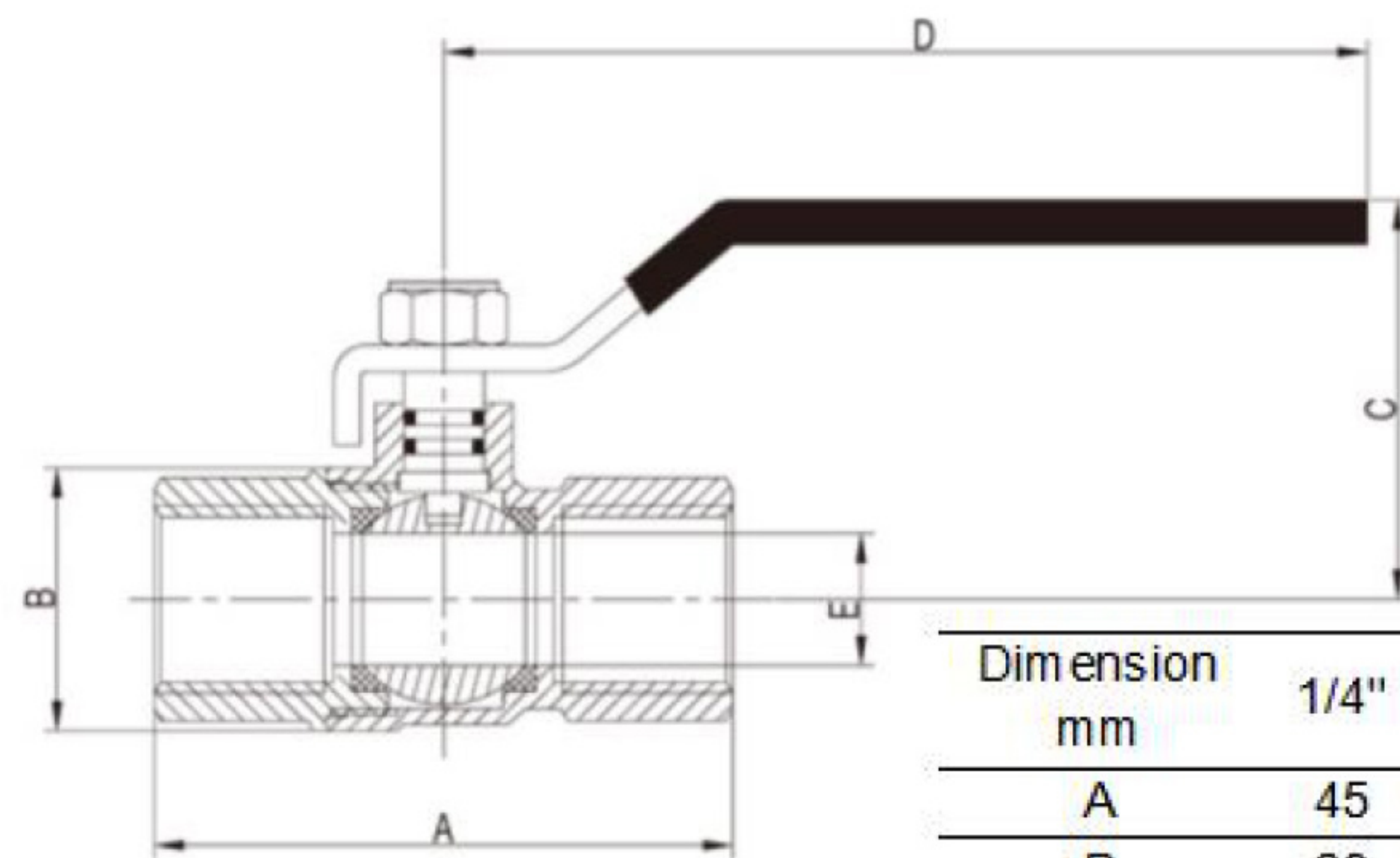

LL1063

Dimension mm	1/4"	3/8"	1/2"	3/4"	1"	1 1/4"	1 1/2"	2"	2 1/2"	3"	4"
A	45	45.8	59.4	67	77	93	99	117	143	165	190
B	23	23	29.5	35	42.7	53	63	79	102.5	120.5	144.5
C	39.2	39.8	54.2	57.6	60.6	75.8	81.3	88.5	121.5	129.5	141
D	87	87	95	95	126	140	140	165	224	224	283.5
E	9	10	14.8	19	24	30.2	37	47	62	74	90
PN	23	25	25	25	25	25	25	25	25	25	25
W(g)	134	126	209	297	479	725	932	1484	2988	4344	6310

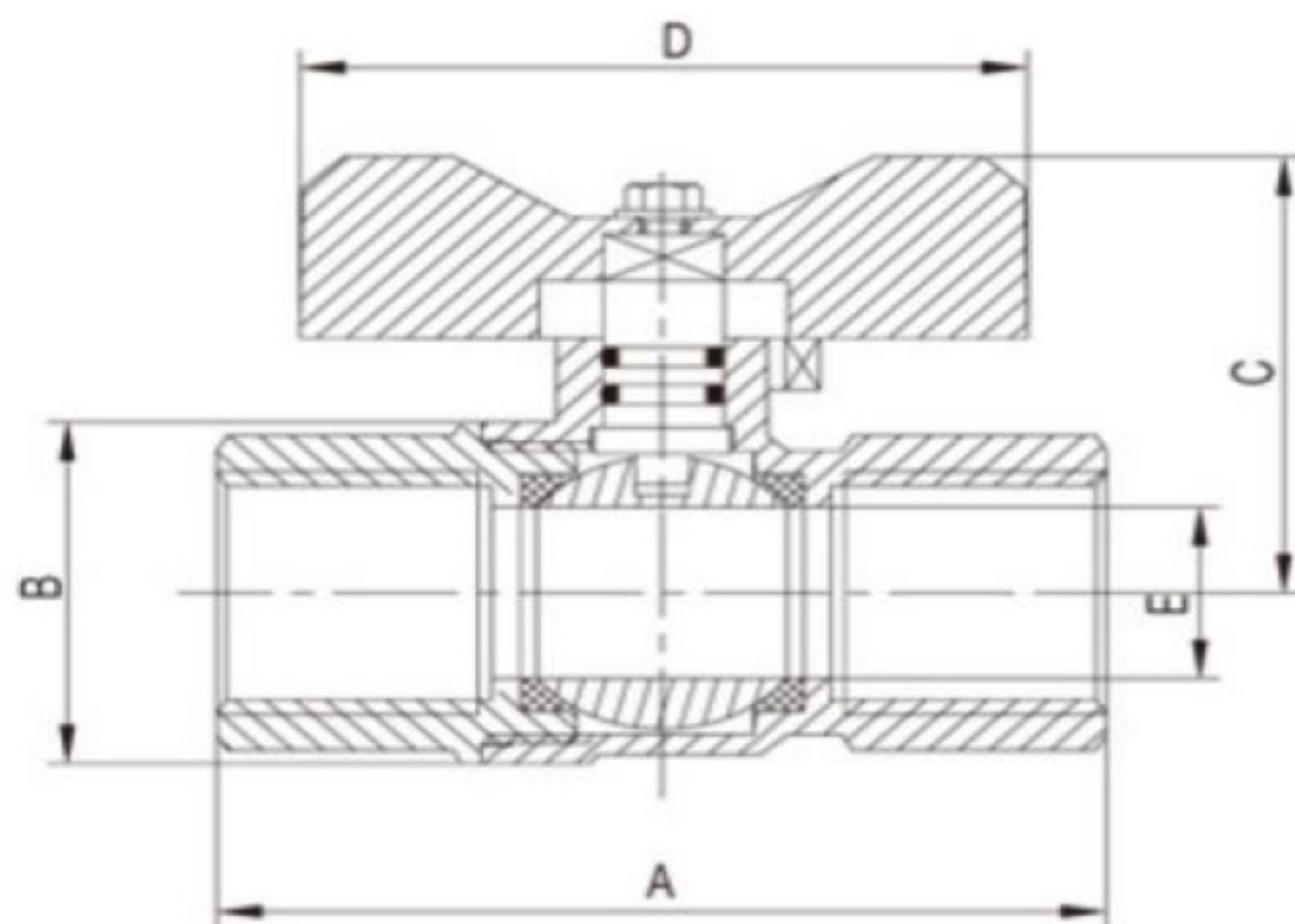

LL1193

Dimension mm	1/4"	3/8"	1/2"	3/4"	1"	1 1/4"	1 1/2"	2"	2 1/2"	3"	4"
A			59.4	67	77						
B			29.5	35	42.7						
C			38.8	42.2	50						
D			54	54	62						
E			14.8	19	24						
PN			25	25	25						
W(g)	134	126	169	255	408	640					

Design and Manufacture

Fields of Use

Materials

General Technical Characteristics

Reference Standards

Specifications

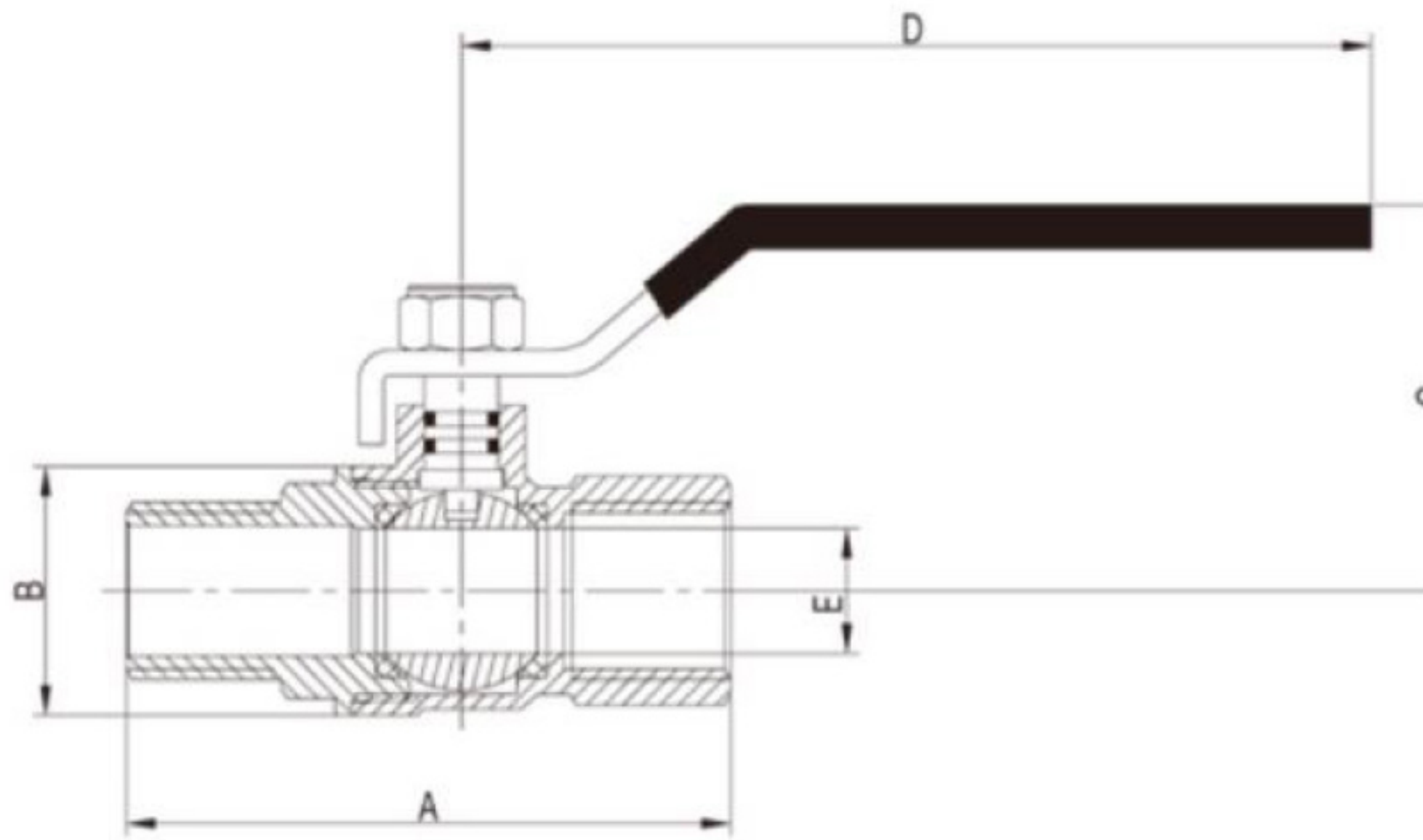

LL1095

Dimension mm	1/4"	3/8"	1/2"	3/4"	1"	1 1/4"	1 1/2"	2"	2 1/2"	3"	4"
A	52.8	53.3	66	72	84.5	100	109	129			
B	23	23	29.5	35	42.7	53	63	79			
C	39.2	39.8	54.2	57.6	60.6	75.8	81.3	88.5			
D	87	87	95	95	126	140	140	165			
E	9	10	14.8	19	24	30.2	37	47			
PN	25	25	25	25	25	25	25	25			
W(g)	135	134	212	278	464	733	952	1546			

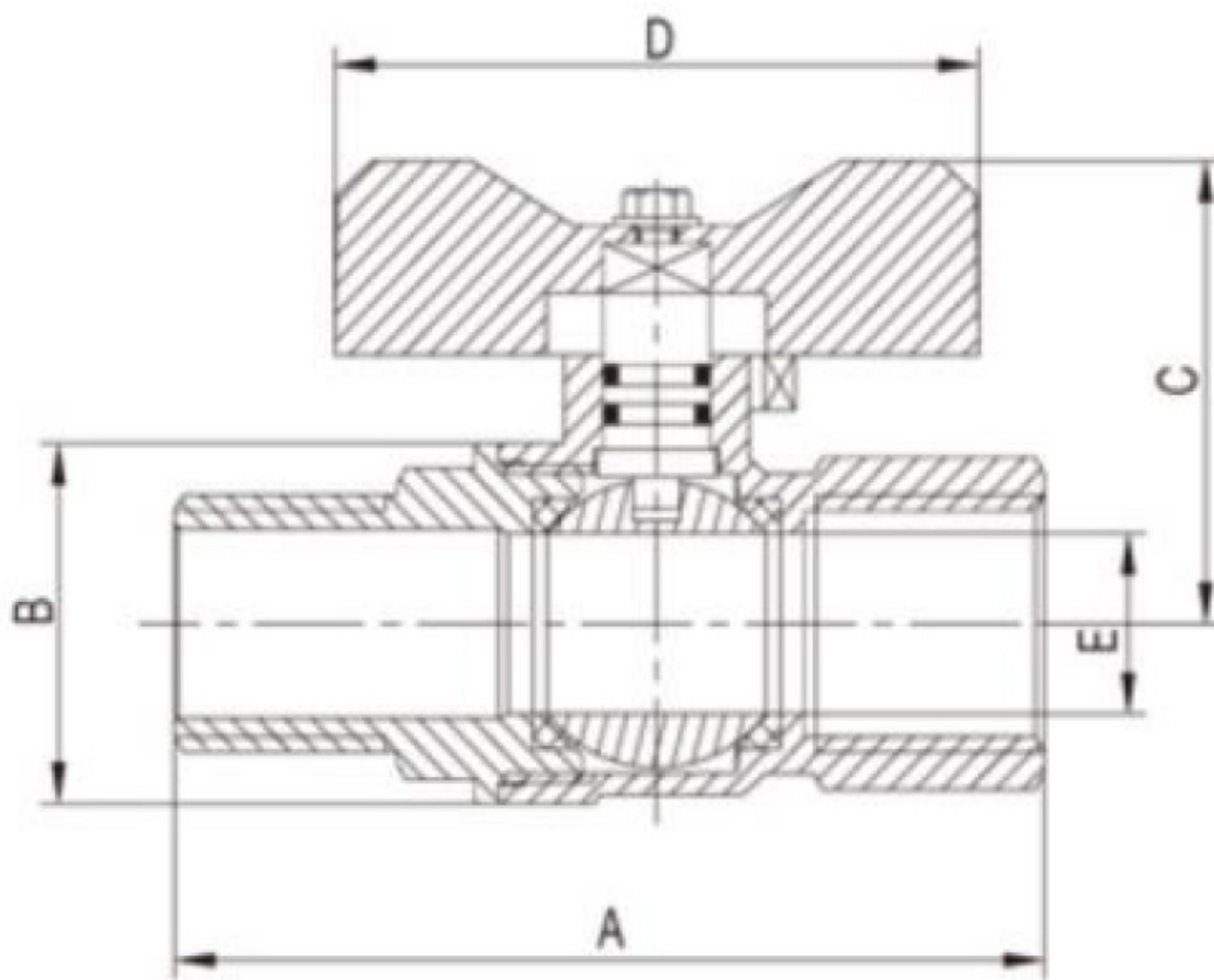

LL1194

Dimension mm	1/4"	3/8"	1/2"	3/4"	1"	1 1/4"	1 1/2"	2"	2 1/2"	3"	4"
A			66	72	84.5						
B			29.5	35	42.7						
C			38.8	42.2	50						
D			54	54	62						
E			14.8	19	24						
PN			25	25	25						
W(g)	135	134	175	249	403	660					

Pressure-temperature chart

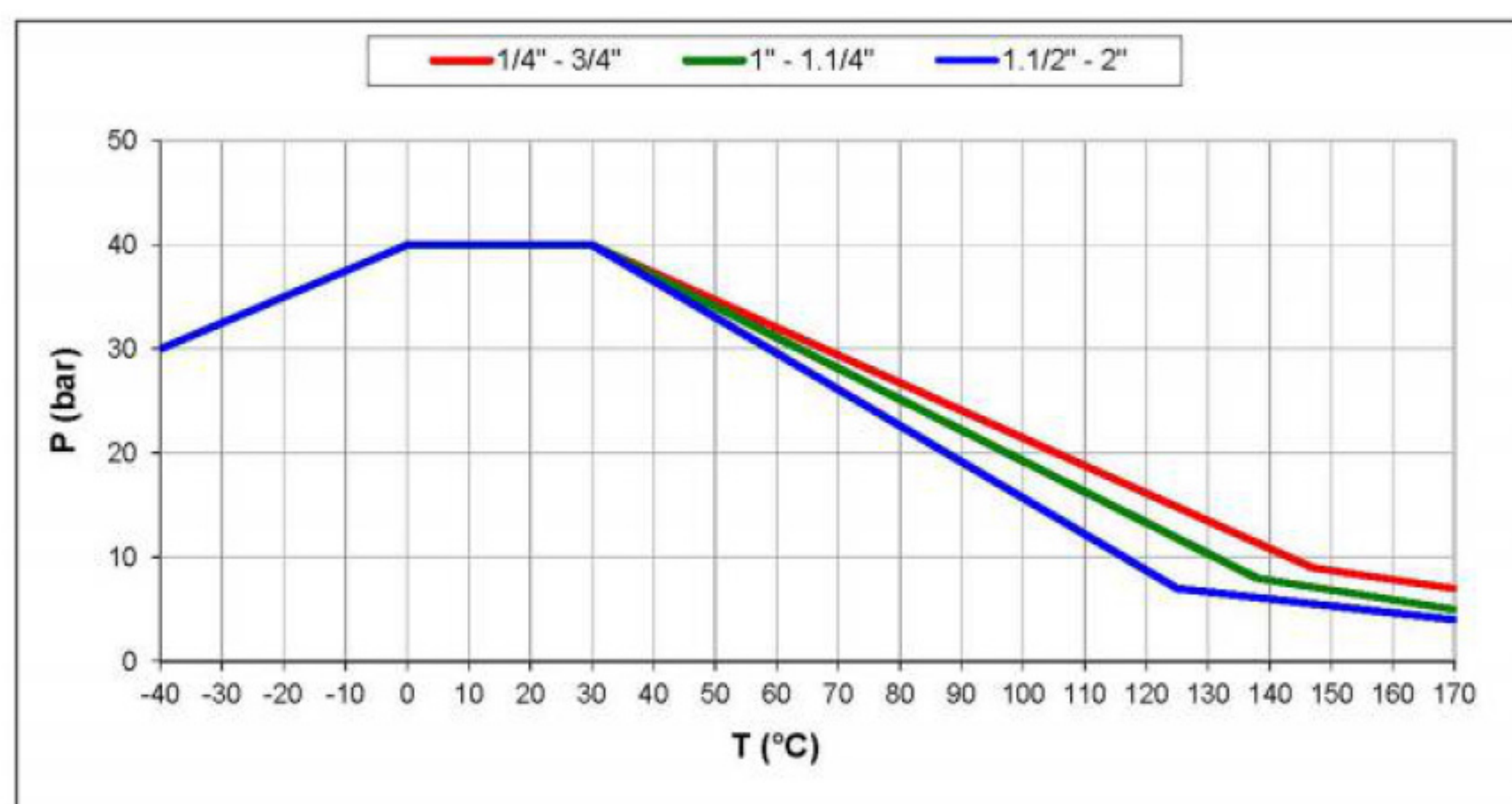

Pressure drop chart

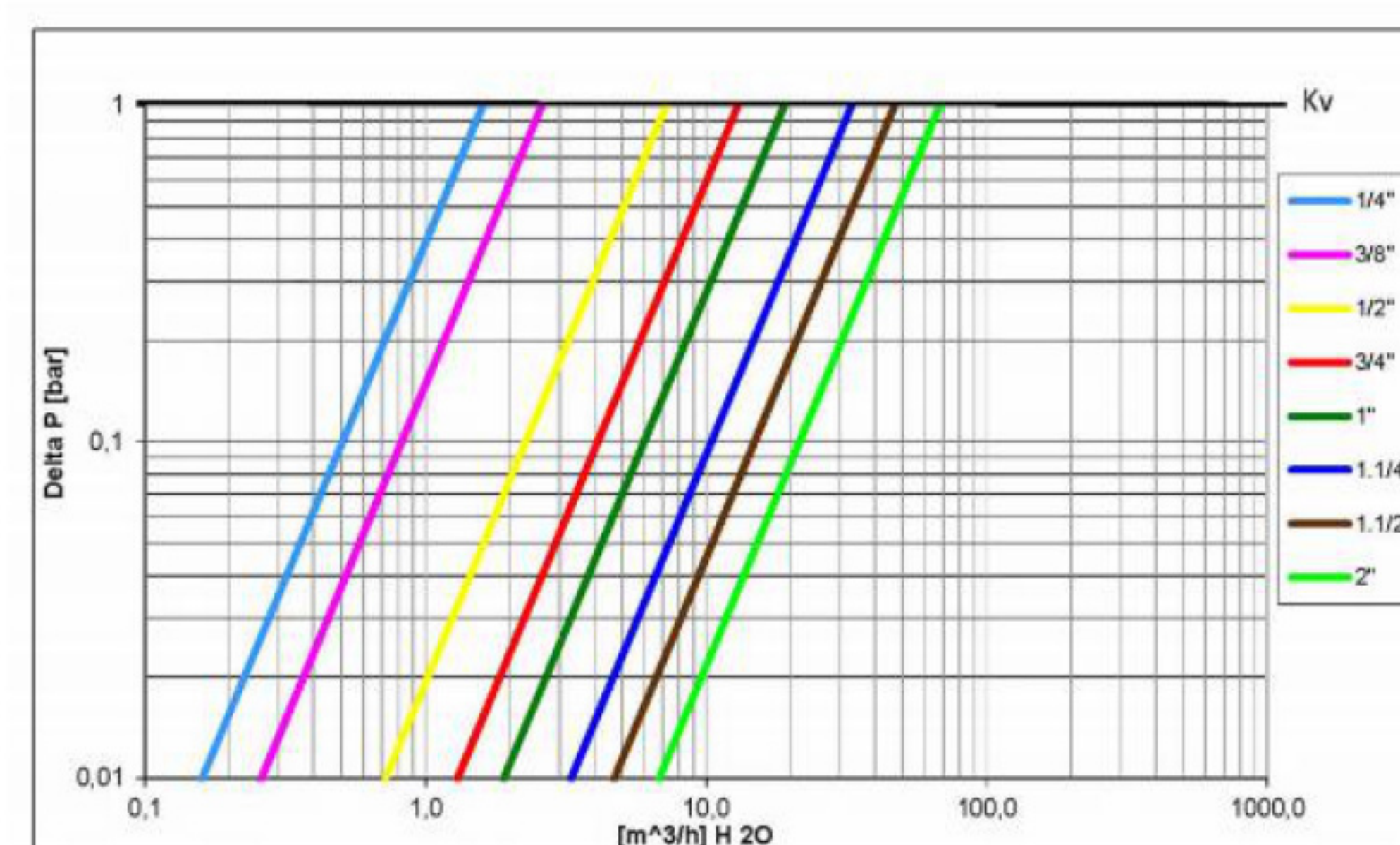

Ask for additional information on the whole range of Ifan products and consult with your supplier for special applications. Ifan endeavors to provide comprehensive information about the installation, maintenance and operation of its products. For more details or clarification, please contact us. Ifan reserves the right to change or modify product design, construction, specifications, materials or the information herein without prior notice and without incurring any obligation to make such changes and modifications on Ifan products previously or subsequently sold. Content of this document is proprietary to Ifan and it may not be copied in part or in whole without prior written authorization from Ifan. Recommendations on application design and material selection are based on available technical data and are offered as suggestions only. Pressure and temperature ranges are for generic use of the products. Each user should make his/her own tests to determine the suitability for his/her own particular use. Ifan offers no express or implied warranties concerning the form fit, or function of a product in any application. Ifan does not accept liability for errors or omissions. Any undated reference to a code or standard shall be interpreted as referring to the latest edition. Ifan and logo are registered trademarks, Other logos are property of respective owners.